

# PRE9275 Hob Run Timer

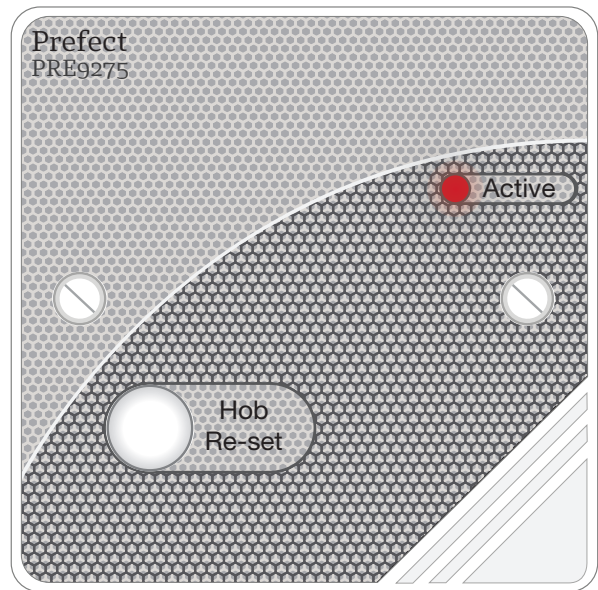

## Operation:

The PRE9275 Hob re-set switch has been designed to limit wasteful use of energy, whilst reducing the potential risk of pan fires by allowing the electric hob fitted in kitchens to run for only 15 or 30 minutes.

After the 15 or 30 minutes has elapsed, the control can be re-activated for a further period.

The PRE9275 is fitted with a single “non latching” push button, on activation the PRE9275 will allow power to flow to the hob for a period of 15 or 30 minutes, indicated by the “Active LED”. After this time period the supply is disconnected.

**Please Note:** This Prefect product is designed to limit the time the hob is powered on. It does not detect fire or alert if a pan fire occurs, therefore this product does not comply with EN 50615

## Installation Instructions:

**WARNING.** This device works at mains potential. Be sure to take care when working with electricity.

1. If fitting to a metal back box ensure that top and bottom lugs are removed.
2. Isolate the mains supply to the circuit at the main consumer unit.
3. Perform safe isolation procedure
4. Connect the PRE9275 in the following manner: connect Live supply to the L terminal, the load to the LIVE OUT terminal and Neutral to the N terminal.
5. Fix the unit to a 45mm or greater surface or sunken back box, take care not to over tighten the mounting screws, over tightening of these screws may deform the fascia resulting in the activation button becoming tight or seized.
6. It is strongly recommended that when the unit is mounted to a

smooth surface, for example an acrylic splash back panel, that a thin bead of silicon is applied around the product. This is highly recommended as the silicone will protect against water or over substance ingress, the silicone bead will also stabilise the unit when mounted onto a smooth surface, as when fitted to such a surface the product may become moderately movable.

7. Switch the mains supply back on at the distribution board.
8. Press the activation button and ensure the button moves freely, ensure the load is functional.
9. Cancel the current cycle by pressing the activation button.

**IMPORTANT NOTICE!** This device should be installed by a qualified electrician in accordance with the latest edition of the IEE wiring regulations.

**NOTICE:** If the PRE9275 does not complete the desired time run, this may be due to transient volt drop. When transient volt drop caused by lighting, ventilation equipment, neon indicators or other, the resulting volt drop may reset the unit if below the minimum operation voltage of 216.2VAC. If this problem occurs fit a PRESCX21uF smoothing capacitor between the Live in and Neutral terminals of the PRE9275. Do not fit more than one capacitor to the hob circuit, only fit the capacitor to the PRE9275, do not terminate the capacitor to any other parts of the hob circuit.

Wiring Diagram:

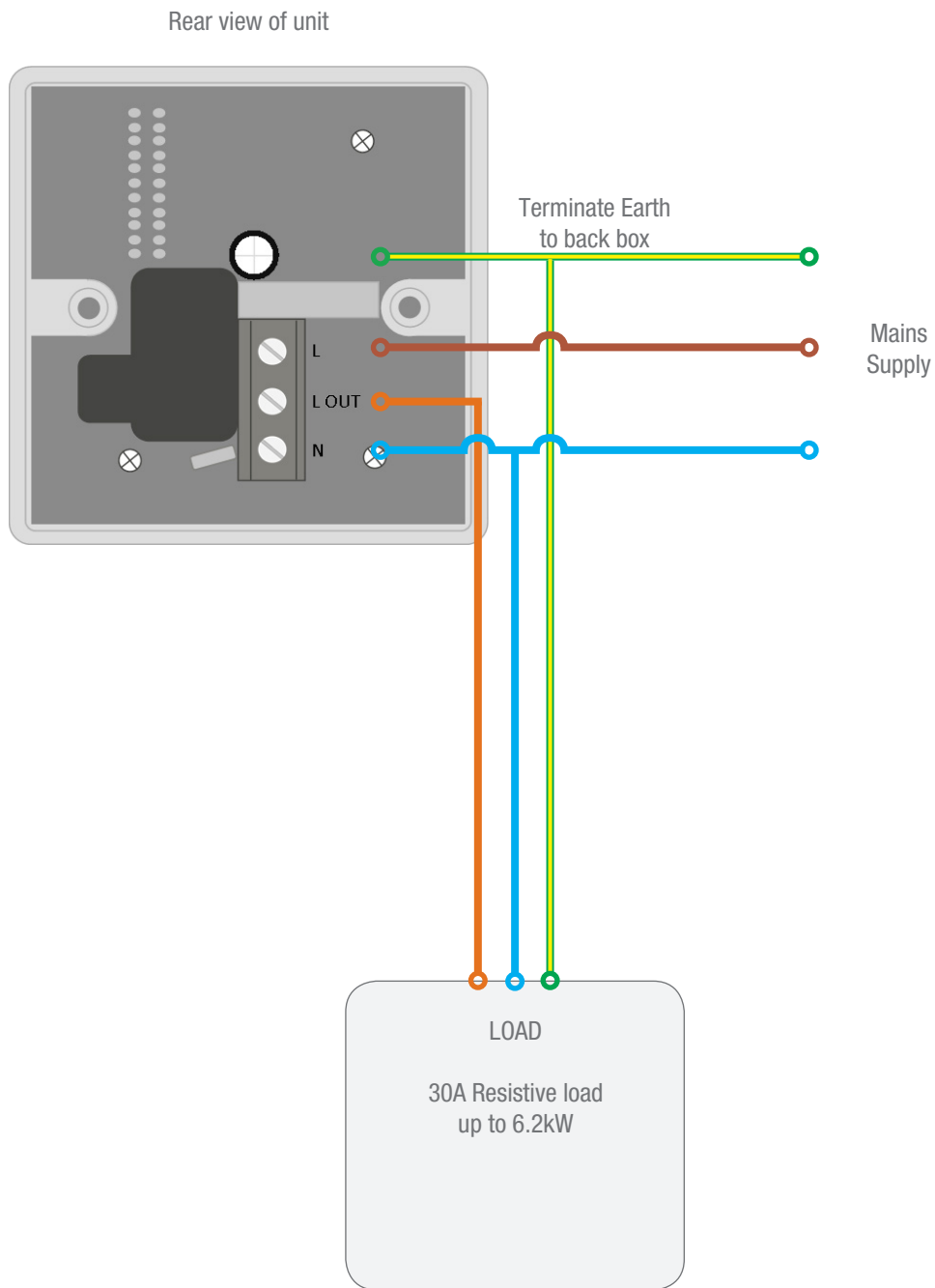

Specification:

**LOAD:** 26 Amp resistive load maximum  
**SUPPLY VOLTAGE:** 216.2-253 Volts AC 50 Hz  
**TIME OUT PERIOD:** 15 or 30 mins selectable only at point of order  
**FIXING METHOD:** Surface fixing 45mm deep plastic surface mount moulded box. Flush fixing 45mm steel wall box or 32mm deep cavity wall box.  
**TERMINAL CAPACITY:** 4.0mm<sup>2</sup>  
**MATERIAL:** Flame retardant ABS Class 2  
**TYPE:** Class 2  
**TEMPERATURE:** -10°C to 35°C

**CONFORMITY:** EMC-89/336/EEC. LVD-73/23/EEC

**WE RECOMMEND THIS PRODUCT BE INSTALLED BY A COMPETENT PERSON IN ACCORDANCE WITH IEE REGULATIONS IN FORCE AT THE TIME.**